

Needle Valves

LG Style



TIMALCO
HYDRAULICS

www.timalco.com.au

Specifications	6	8	10	12	16	20
Max Pressure MPa	31.5					
Max Flow L/min	14	40	60	85	175	200
Hydraulic Fluid	Mineral oil; phosphate-ester					
Fluid Temp °C	-20~70					
Viscosity mm ² /s	2.8~380					

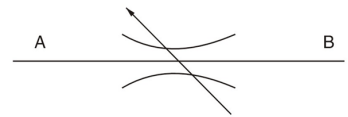
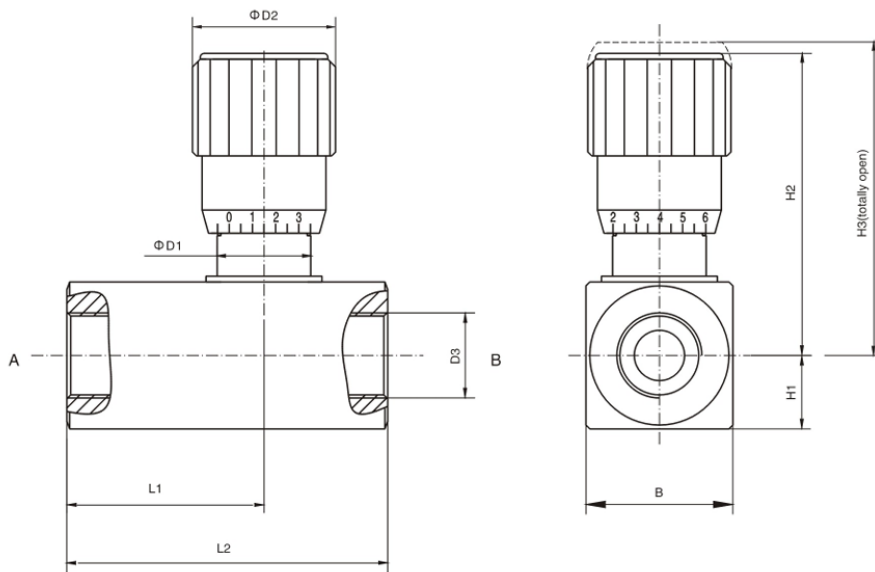

Model	B	D1	D2	D3	H1	H3	L1	L2
G6	28	19.3	30	G1/8"	14	64.8	26	48
G8	28	19.3	30	G1/4"	14	67.9	28	54
G10	28	19.3	30	G3/8"	14	67.5	28	54
G12	38	24.2	37	G1/2"	19	86.5	34	68
G16	38	24.2	37	G3/4"	19	86.5	39	78
G20	48	35	48	G1"	24	114.4	45.8	92