

Gear Box 3:1 Cast Iron Heavy Duty



www.timalco.com.au

KMT7001-4A



KMT7002-4A



KMT7004-4A



Cast Iron 700 Series Speed Increaser 3:1

Part Number	Input Type	Pump Mount
KMT7001-4A	Male 1 3/8"	Group 2/3
KMT7002-4A	Female 1 3/8"	
KMT7004-4A	Female 6T + Lock 1 3/8"	

Input Torque (Nm)	Output Torque (Nm)	Input Speed (rpm)	Output Speed (rpm)	Transmission Ratio	Power (KW)	Weight (Kgs)
660	220	540	1620	3:1	37	16

Ordering Code

KMT	700	1	4	A	*
KM = Speed Increaser (Aluminium Body)	600 Series	PTO Input 1 = Male 1 3/8" DIN 9611	Transmission Ratio: 4 = 1:3.0	Mounting Position A = Standard	Flange: Omit for Group 2 & 3 Pumps
KMT = Speed Increaser (Cast Iron Body)	700 Series	2 = Female 1 3/8" DIN 9611 4 = Female 1 3/8" DIN 9611 + Locking			T = SAE B (96101) W = SAE A (96100)

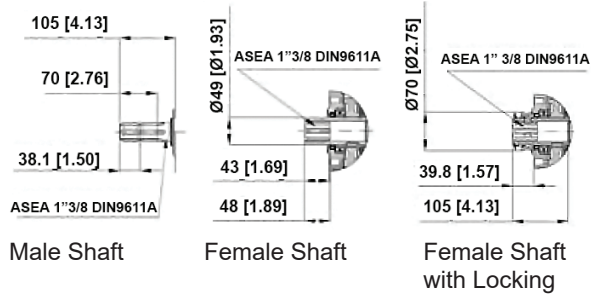

P.T.O Input

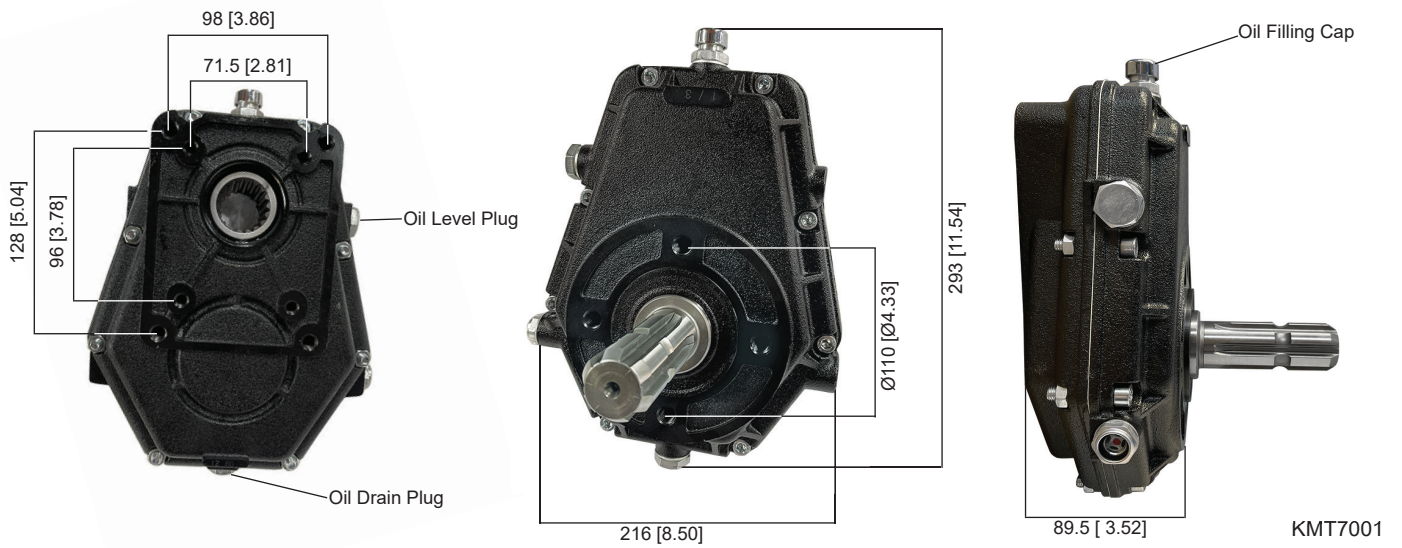

Dimensional Views: Back, Front, Side



Flanges - Pump Mount

	Part Number	Description
	KM60100	KM Gear Box to SAE A 2 Bolt Mount Pump
	KM96101	KM Gear Box to SAE B 2 Bolt Mount Pump

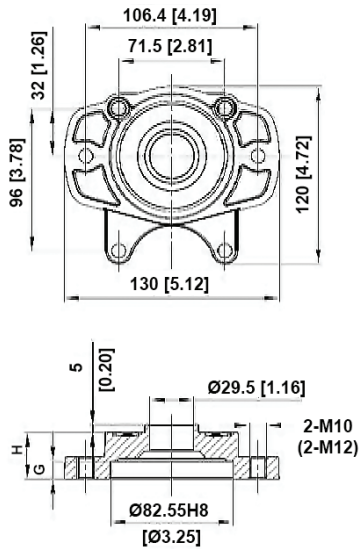

KM60100 Flange Dimensions

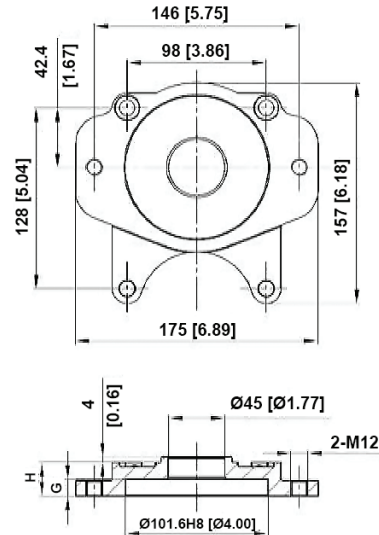

KM96101 Flange Dimensions



Couplings

	Part Number	Description
	KM10005	KM600 to Grp 2 1:8 Taper Pump
	KM10007	KM25603 Support to Grp 2 1:8 Taper Pump
	KM10012	KM700 to Grp 2 1:8 Taper
	KM10014	KM700 to Grp 3 1:8 Taper Pump
	KM15002	KM700 to SAE B 7/8" Str Keyed Pump
	KM35505	KM700 to SAE B 13T Splined Pump
	KM35517	KM600 to SAE A 9T Splined Pump