

THM Cetop 3 Manifolds



TIMALCO HYDRAULICS

Parallel

www.timalco.com.au



LPRS2-10 Pilot Operated Relief Valve

Alloy Parallel with plugged Relief Cavity

Part Number	Ports		Description	L Dim mm	L1 Dim mm
	P & T	A & B			
THMC3P1AC	1/2" BSPP	3/8" BSPP	Single Station	90	74
THMC3P2AC	1/2" BSPP	3/8" BSPP	2 Station	137	121
THMC3P3AC	1/2" BSPP	3/8" BSPP	3 Station	192	176
THMC3P4AC	1/2" BSPP	3/8" BSPP	4 Station	247	231
THMC3P5AC	1/2" BSPP	3/8" BSPP	5 Station	302	286
THMC3P6AC	1/2" BSPP	3/8" BSPP	6 Station	357	341
THMC3P6ACXL	1/2" BSPP	3/8" BSPP	6 Station	457	441

Steel Parallel with plugged Relief Cavity

Part Number	Ports		Description	L Dim mm	L1 Dim Mm
	P & T	A & B			
THMC3P1SC	1/2" BSPP	3/8" BSPP	Single Station	90	74
THMC3P2SC	1/2" BSPP	3/8" BSPP	2 Station	137	121
THMC3P3SC	1/2" BSPP	3/8" BSPP	3 Station	192	176
THMC3P4SC	1/2" BSPP	3/8" BSPP	4 Station	247	231
THMC3P5SC	1/2" BSPP	3/8" BSPP	5 Station	302	286
THMC3P6SC	1/2" BSPP	3/8" BSPP	6 Station	357	341

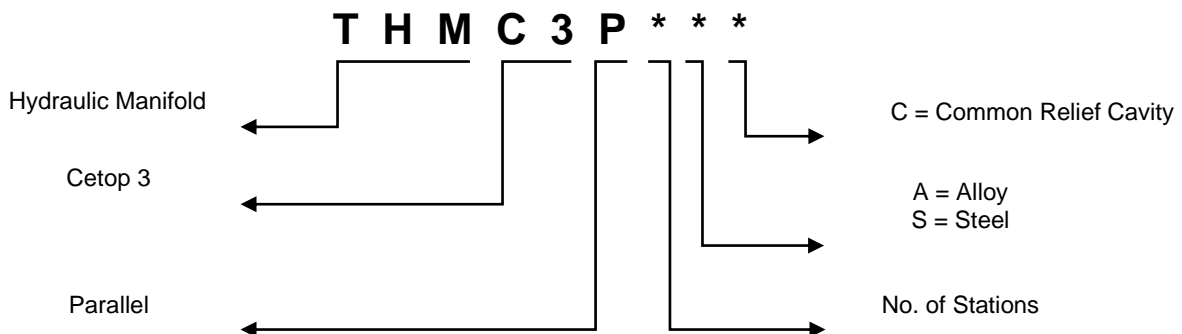

08 8262 4333



Timalco Hydraulics



timalcohyd

Manifold Schematic

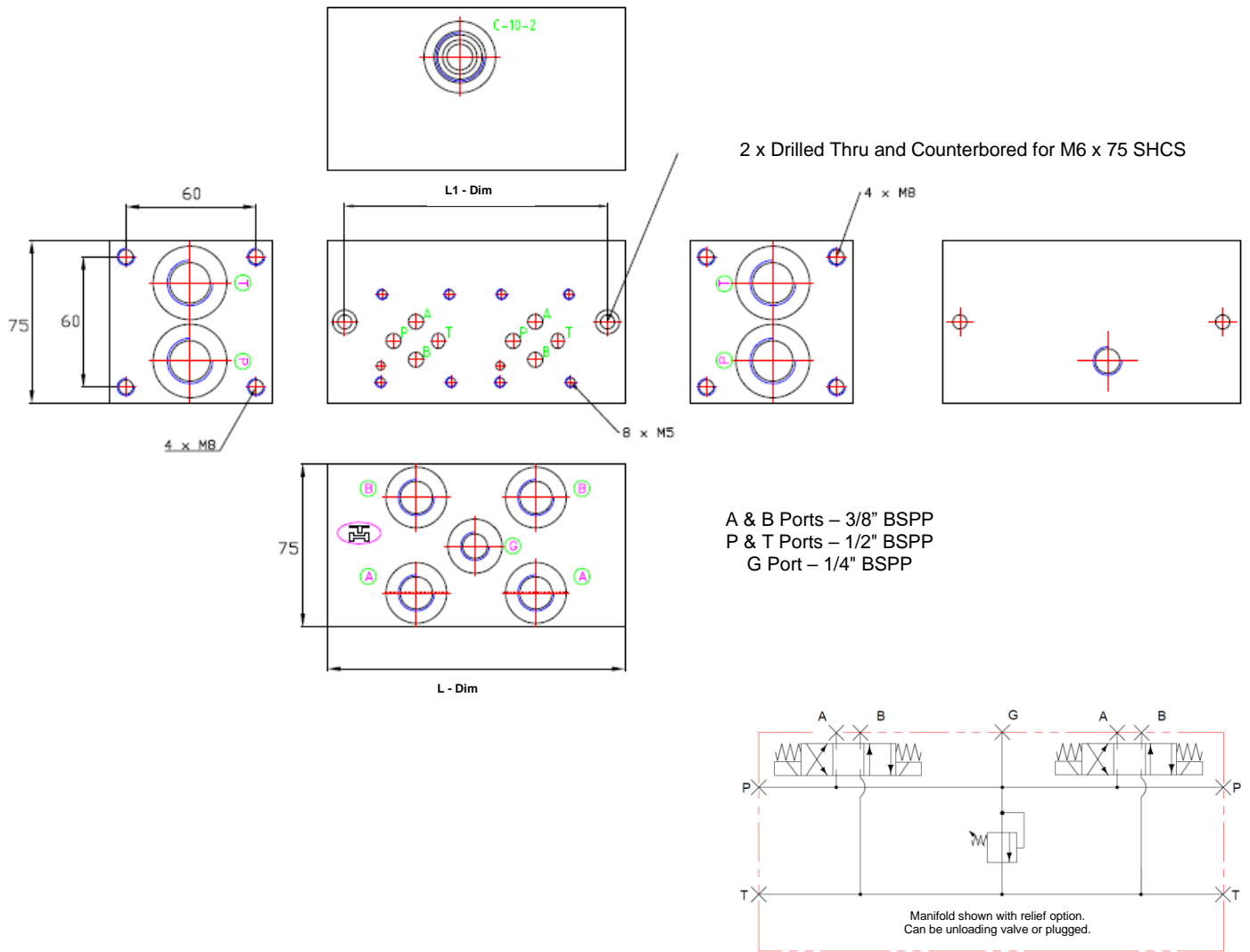

Manifold Foot Bracket

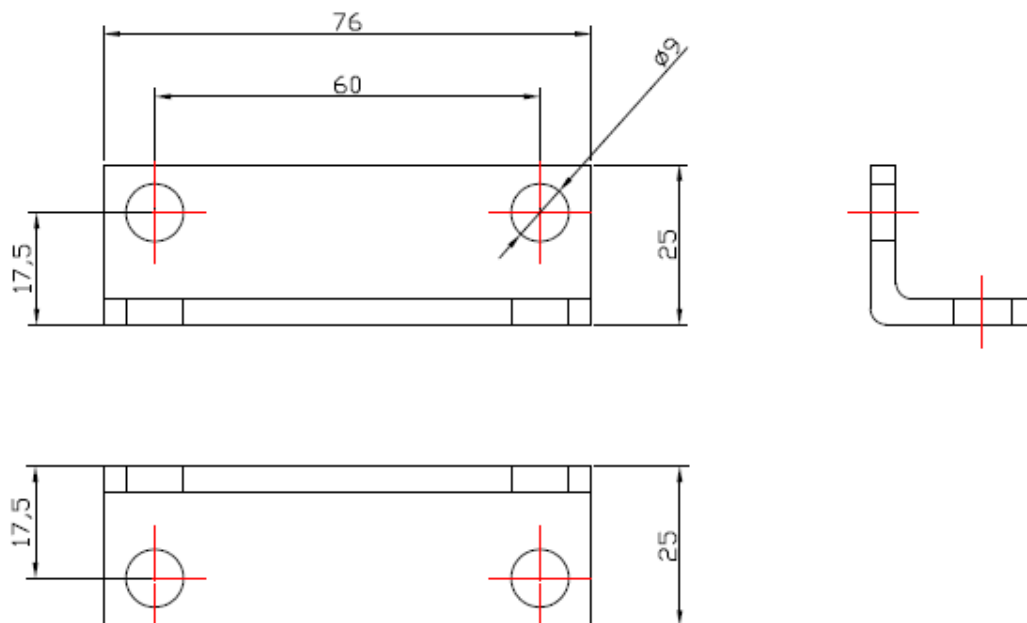

08 8262 4333



Timalco Hydraulics



timalcohyd