

Valvola OVERCENTER compensata in pressione semplice effetto in linea
In line, single effect pressure compensated COUNTERBALANCE valve

mod. OVC-SE-L-CC

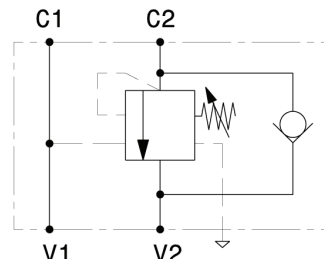
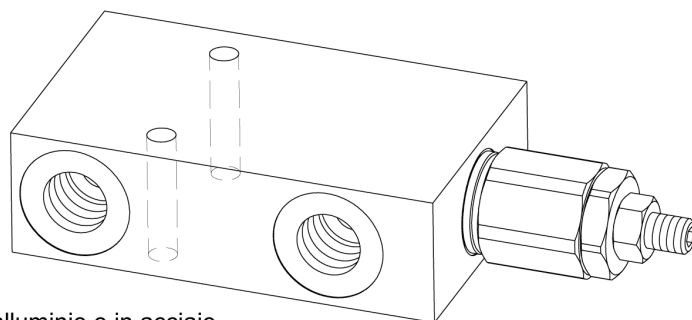

Versione con corpo in alluminio o in acciaio
Aluminium or steel body version

Pressione massima <i>Max pressure</i>	350 bar <i>5000 psi</i>
Rapporto di pilotaggio standard <i>Standard pilot ratio</i>	4,25:1
Rapporto di pilotaggio a richiesta <i>Pilot ratio upon request</i>	3:1 8:1 10:1

Dati e tarature ottenuti usando olio con viscosità 30 cSt a 50°C
Performances and calibrations are carried out by using hydraulic oil with 30 cSt viscosity at 50°C

Viscosità consigliate <i>Recommended viscosity</i>	10 ÷ 420 cSt
Temperature di lavoro <i>Working temperature</i>	-20 ÷ +90 °C
Filtrazione assoluta <i>Absolute filtration</i>	25 µ

Modello <i>Type</i>	V1, V2 C1, C2	Portata max <i>Max. flow</i>
OVC-SE-L-CC-38	3/8" GAS	40 l/min 10.5 gpm
OVC-SE-L-CC-12	1/2" GAS	60 l/min 16 gpm
OVC-SE-L-CC-34	3/4" GAS	100 l/min 26 gpm
OVC-SE-L-CC-10	1" GAS	120 l/min 32 gpm

Taratura Setting
 La valvola deve essere tarata almeno 1.3 volte la massima pressione indotta dal carico
The valve must be set at least 1.3 times maximum load induced pressure

Codice <i>Code</i>	Taratura standard <i>Standard setting (Q=5 l/min)</i>	Campo di taratura <i>Adj. Pressure range</i>	Colore molla <i>Spring color</i>
01	100 bar <i>1450 psi</i>	20+200 bar <i>290+2900 psi</i>	Bianco <i>White</i>
02	280 bar <i>4000 psi</i>	50+350 bar <i>725+5000 psi</i>	Nero <i>Black</i>

Regolazioni - Adjustments

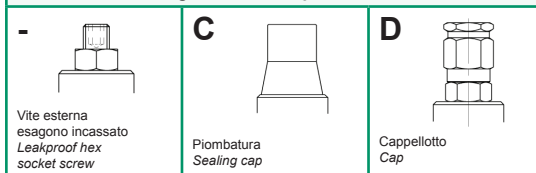

Sigla di ordinazione / Ordering code

OVC-SE-L-CC-38	02	-	-
Modello <i>Type</i>	Codice taratura <i>Setting code</i> 01, 02	Codice regolazione <i>Adjustment code</i> -, C, D	- Alluminio / Aluminium A Acciaio / Steel

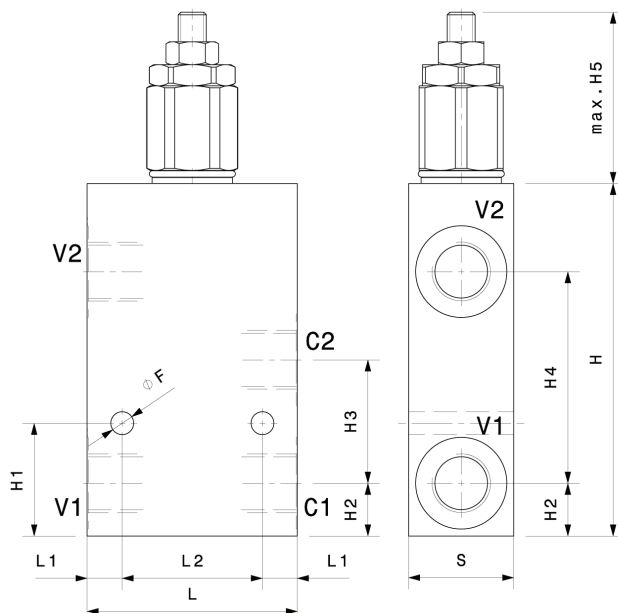

Modello <i>Type</i>	L	H	S	L1	L2	H1	H2	H3	H4	H5	F
OVC-SE-L-CC-38	60	100	30	10	40	32	15	35	60	42	6.5
OVC-SE-L-CC-12	60	100	30	10	40	32	15	35	60	42	6.5
OVC-SE-L-CC-34	70	125	40	10	50	42.5	20	45	80	48	8.5
OVC-SE-L-CC-10	70	140	50	10	50	51	25	52	90	48	8.5

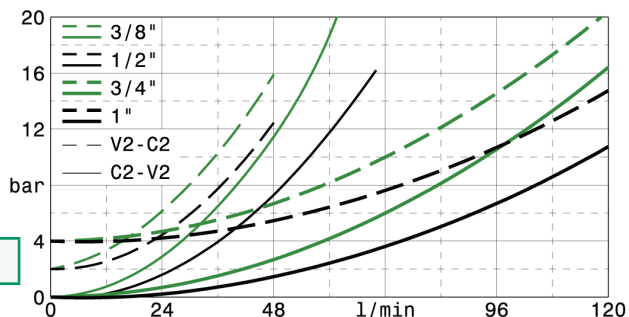

I dati non sono impegnativi, CBF si riserva di apportare modifiche senza preavviso.
The specifications are not binding, CBF reserves the right to introduce modifications without notice.